



LOCATION		DATE
PREPARED BY		QUANTITY
COMMENTS		FIXTURE TYPE
CATALOG NUMBER		

Stratford LED Outdoor Sconce SATW Series

Features

Modern Outdoor LED wall lantern with clear crackle glass. Dusk-to-Dawn Photocell turns light on at night and off in the morning. The lantern mounts to a standard electrical box.

Construction

All aluminum die-cast housing. Power supply connections must be made inside a junction box (not included).

Finish

Black powder coat finish.

Diffuser

Clear blown glass diffuser features a crackle pattern for an attractive light dispersion.

Electrical

Input 120 VAC 60 HZ .09A with integrated photocell. Minimum operating temperature -20° F.

LED

Integrated LED module capable of producing: 11W, 1100 source lumens 3000K (CCT). Rated for 50,000 Hrs. 90 CRI.

Certification

All fixtures are cETLus listed for wet locations.

Warranty

Limited warranty: This fixture is free from defects in materials and workmanship for a period of 5 years from date of purchase.

**Specifications and dimensions
subject to change without notice.**

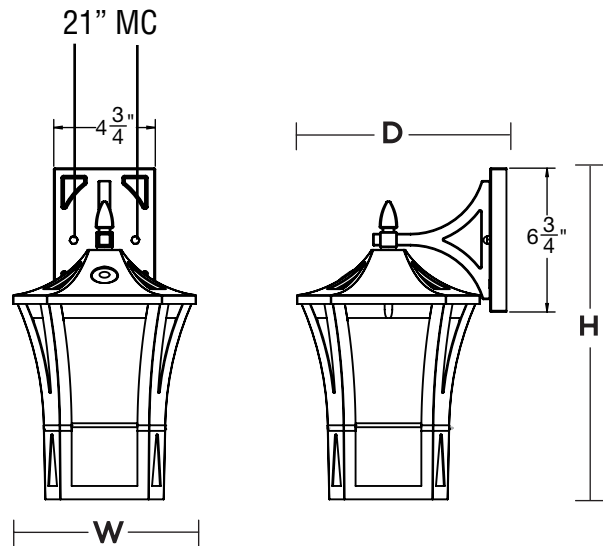

Ordering Information:

Black	LED	Source Lumens	CCT	H	W	D
SATW091508L30ENBK	11W	1100	3000K	15-1/4"	8-1/2"	9-3/4"