



Diamond Tub & Showers Spec Sheet

Model: TC 603677 R/L Right Shown

Description: Tub/Shower Combo 1 Piece Unit

Specifications

Model #	Material	Wall Finish	Pieces	Drain	Apron Height	Net Weight Lbs.
TC 603677	Fiberglass/Gelcoat	Smooth	1	LH/RH	18"	

Sump Data

Top of Drain to Bottom of Overflow	Capacity to Overflow Gallons	Top Dimensions		Bottom Dimensions	
		Length	Width	Length	Width
12 1/2"	54.8	52 7/8"	26 1/2"	44"	22 1/2"

Framing Dimensions

A	B	C	D
60"	17"	8 1/4"	36 1/8"

Enclosure Opening

Length	Width
56.3/4"	57 5/8"

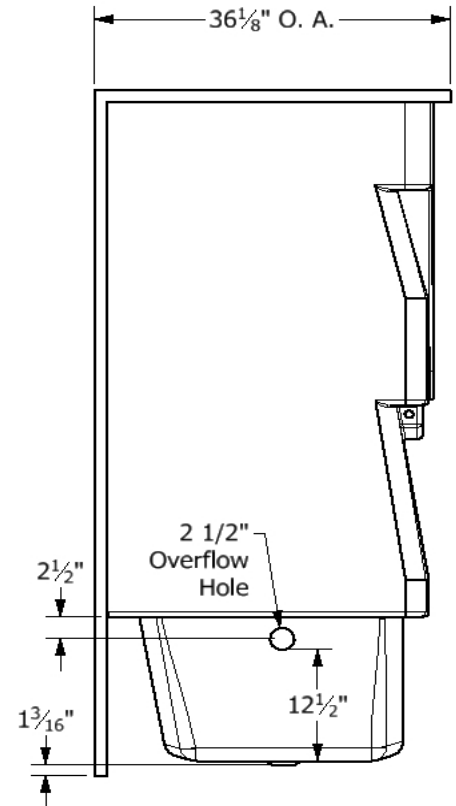
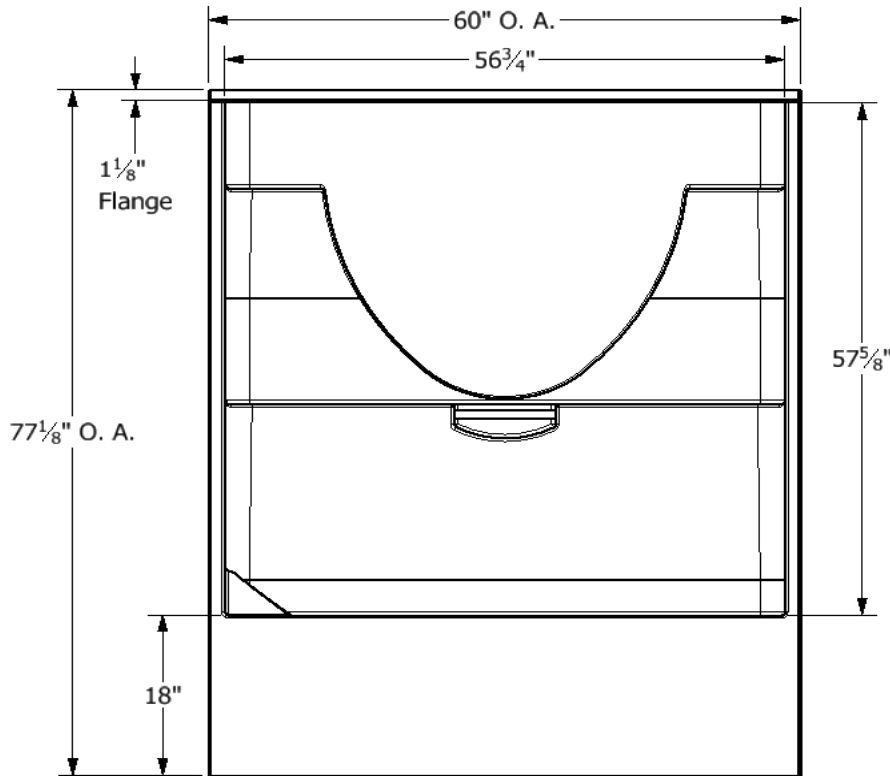
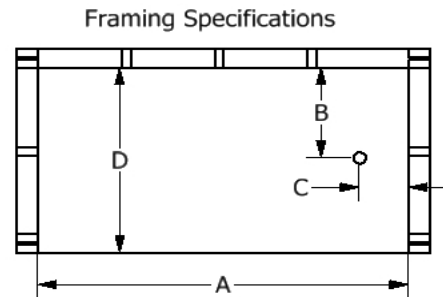
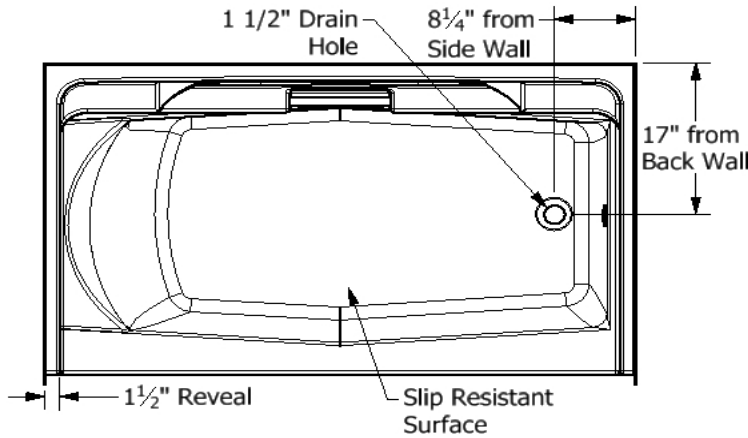

This product is tested by ICC-ES and is certified to conform to the requirements of CSA B45.5/IAMPO Z124 standard.

Manufactured by Front Line Mfg., Inc. Warsaw, IN



7/23/19