



# Diamond Tub & Showers Spec Sheet

Model: THR4 603480 R/L

Description: Tub & Shower Remodeler 4 Piece (pin style) with Grab Bars and Seat

## Specifications

Model #	Material	Wall Finish	Pieces	Drain	Apron Height	Net Weight Lbs.
TRH4 603480	Fiberglass/ Gelcoat	Smooth	4	LH/RH	17"	

## Sump Data

Top of Drain to Bottom of Overflow	Capacity to Overflow Gallons	Top Dimensions		Bottom Dimensions	
		Length	Width	Length	Width
9 15/16"	40.8	53 1/4"	25"	45"	20 1/2"

## Framing Dimensions

A	B	C	D
60 1/8"	8 3/8"	16 1/8"	34 1/4"

## Enclosure Opening

Length	Width
54 1/2"	60 7/8"

## Framing Specifications

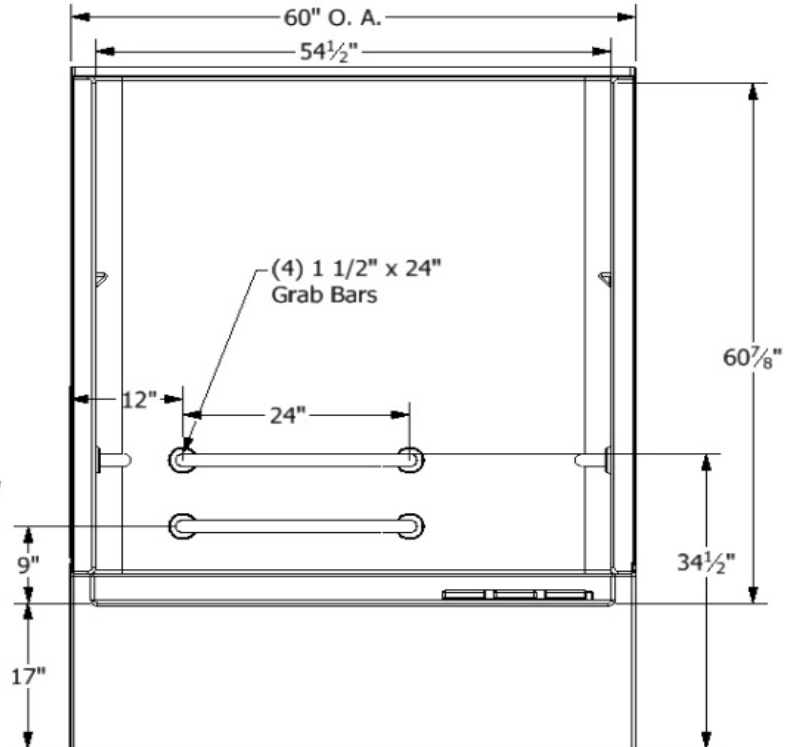
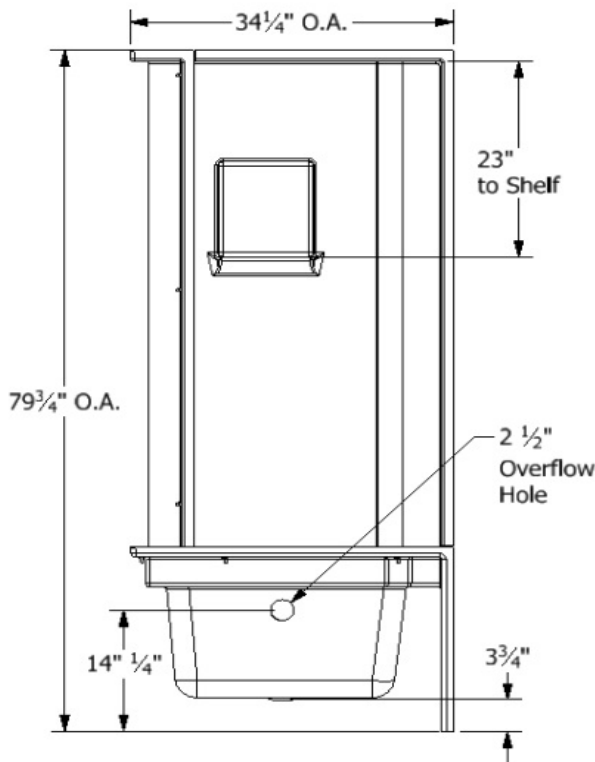
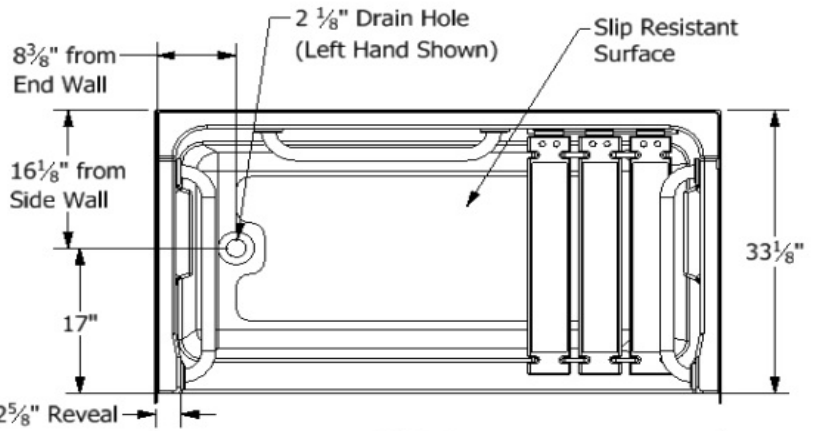
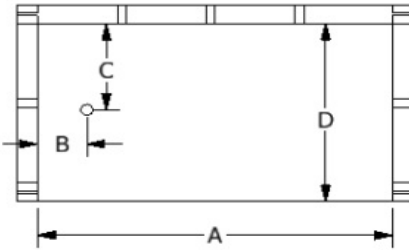

This product is tested by ICC-ES and is certified to conform to the requirements of CSA B45.5/IAMPO Z124 standard.

Manufactured by Front Line Mfg., Inc. Warsaw, IN



5/31/19