



Diamond Tub & Showers Spec Sheet

Model: TN 603173 R/L Right Shown

Description: Tub/Shower Combo 1 Piece Unit

Specifications

Model #	Material	Wall Finish	Pieces	Drain	Apron Height	Net Weight Lbs.
TN 603173 R/L	Fiberglass/ Gelcoat	Smooth	1	LH/RH	14 1/4"	

Sump Data

Top of Drain to Bottom of Overflow	Capacity to Overflow Gallons	Top Dimensions		Bottom Dimensions	
		Length	Width	Length	Width
9 1/2"	41.2	56 1/8"	22 7/8"	49 5/8"	22 7/8"

Framing Dimensions

A	B	C	D
60 1/8"	14 1/2"	7 1/2"	31 1/8"

Enclosure Opening

Length	Width
56.3/4"	57 3/4"

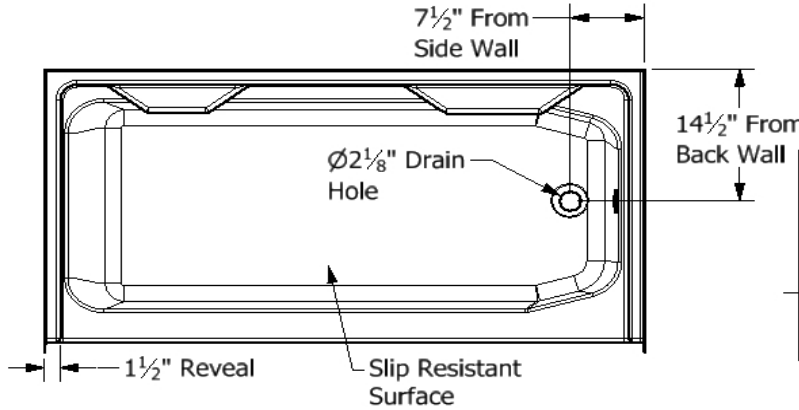

Framing Specifications

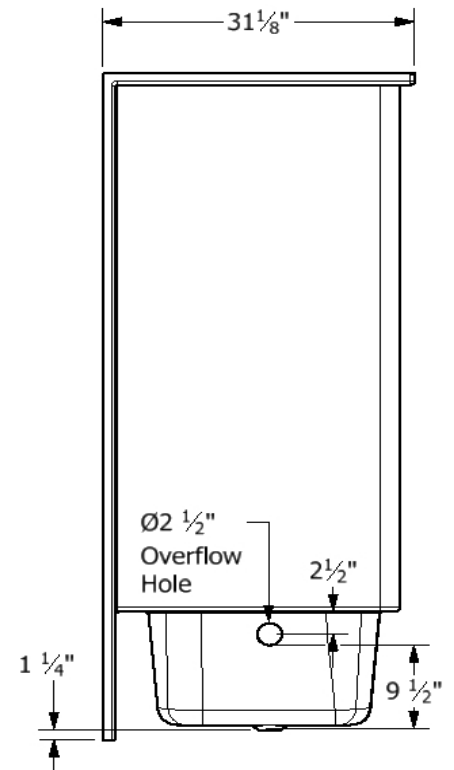
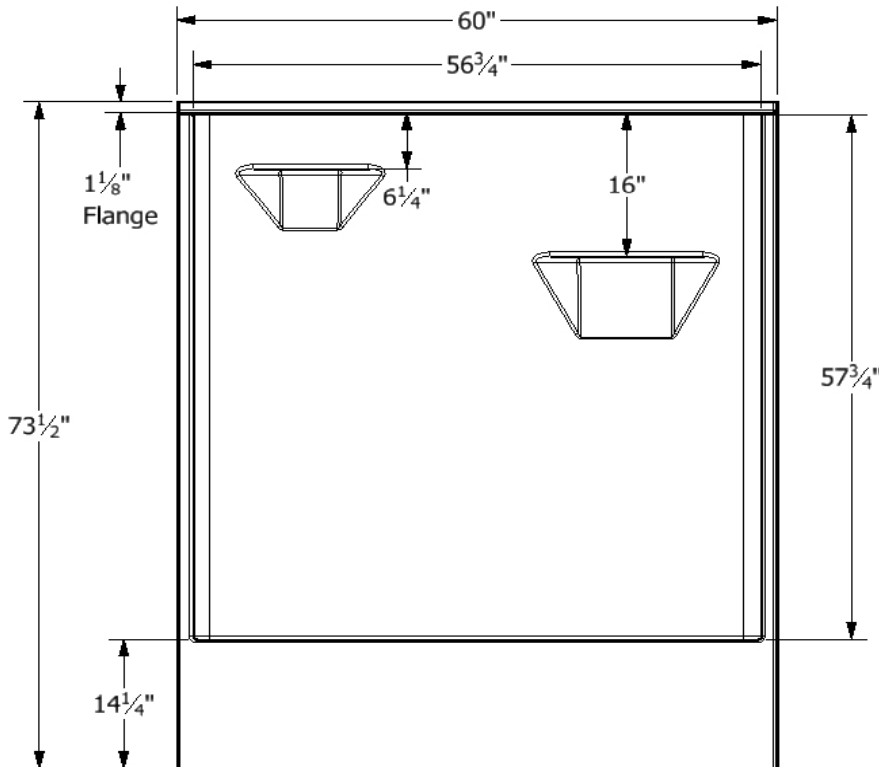
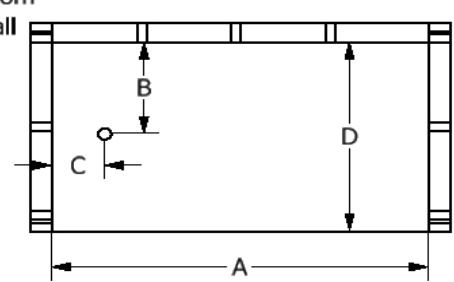

This product is tested by ICC-ES and is certified to conform to the requirements of CSA B45.5/AMPO Z124

Manufactured by FrontLine Mfg., Inc. Warsaw, IN



7/22/19