



Diamond Tub & Showers Spec Sheet

Model: TOCWF 6025

Description: Drop In Corner Tub with Wainscot and Nailing Flange

Specifications

Model #	Material	Wall Finish	Pieces	Drain	Apron Height	Net Weight Lbs.
TOCAWF 6025	Fiberglass/ Gelcoat	Smooth	1	Front Center	NA	

Sump Data

Top of Drain to Bottom of Overflow	Capacity to Overflow Gallons	Top Dimensions		Bottom Dimensions	
		Length	Width	Length	Width
15 1/4"	87.5	NA	NA	NA	NA

Framing Dimensions

A	B	C	D
60 1/8"	19 3/4"	52 3/8"	29 3/4"

Nailing Flange
1 1/8"

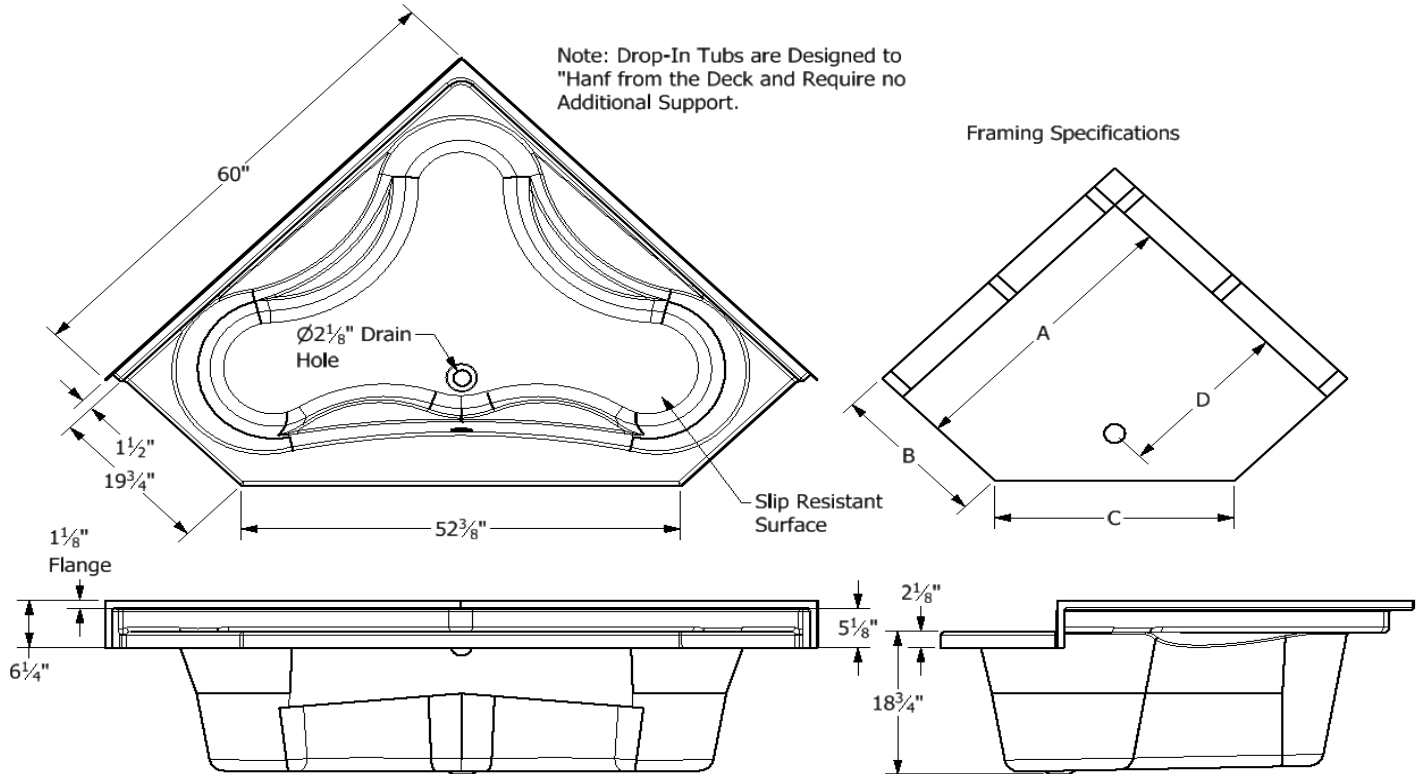

This product is tested by ICC-ES and is certified to conform to the requirements of CSA B45.5/IAMPO Z124 standard.

Manufactured by Front Line Mfg., Inc. Warsaw, IN



5/31/19