

PANT RACK SERIES
Installation Instructions
for the PPR-1814, PPR-2414, PPR-3014

IMPORTANT:

Before you begin, make sure you familiarize yourself with all the parts and fully read the instructions.

CUSTOMER SERVICE:

Toll free customer help line available weekdays between 7:00am and 6:00pm Central Time at 800-463-0660.

TOOLS NECESSARY:

Screw gun or Phillips screwdriver. NOTE: If screw gun has a clutch, set to lowest setting so as not to over tighten and/or strip screws.

PARTS IDENTIFICATION:

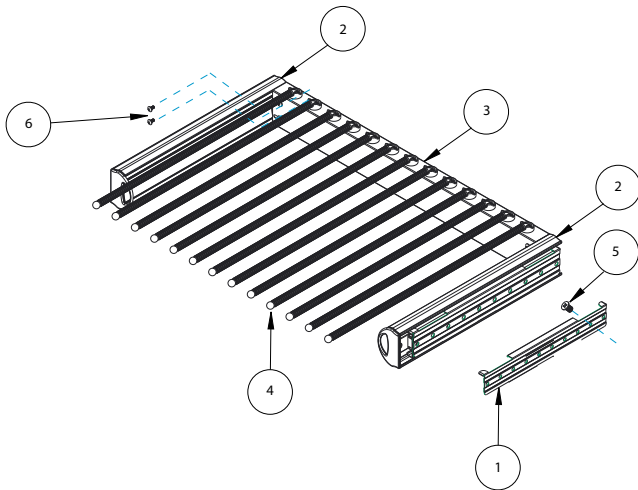

1	Mounting Bracket	qty 2
2	Pant Rack Slide Covers	qty 2
3	Pant Rack Cross Member	qty 1
4	Pant Hanger	PPR-1814 qty 9
		PPR-2414 qty 13
		PPR-3014 qty 16
5	5 mm Euro Screw	qty 4
6	Color coated Pan Head Machine Screw	qty 4

STEP 1



Determine mounting location and install the mounting bracket with the arrows pointing up with the 5 mm Euro screws provided.

STEP 2



Separate slide by compressing the black release clip.

STEP 3

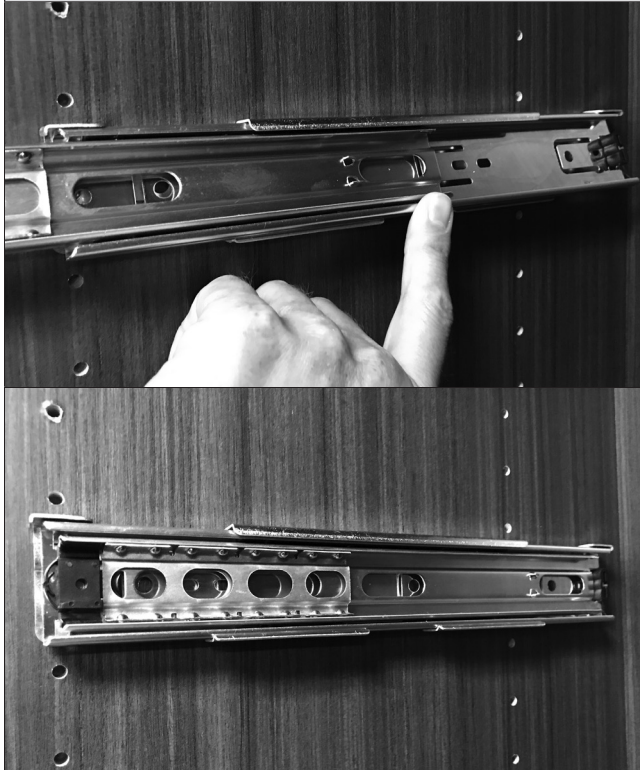

Install cabinet member of the slide into the mounting bracket. Angle the top in first and then snap into place.

STEP 4



Install Cross Member to Slide Cover by sliding the angle brace inside the Cross Member making sure the slotted pant hanger holders are pointing upward. Loosely fasten with 2 – Pan Head Machine screws provided.

STEP 5



Install the Pant Rack organizer back onto the slide. Cycle the unit a couple of times to be sure it is not binding, allowing the Cross Member to center between the Slide Covers. Securely tighten the machine screws.

STEP 6

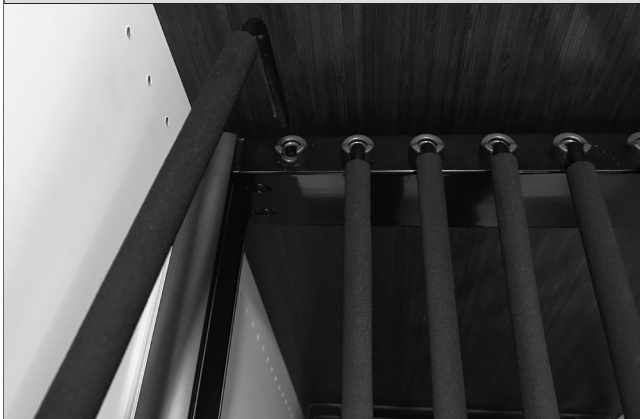

Install the pant rack hangers.